

# **Advance Passenger Information China Implementation Guide - UN/EDIFACT PAXLST**

Version: 1.0.3

Status: Release

Date: Jul 18, 2008

**The Ministry of Public Security of the People's Republic of China  
Civil Aviation Administration of China**

This page is intentionally left blank.

## Revision History

Date	Version	Major Changes
07/18/2008	1.0.3	1) Updated section "Internet Technologies" 2) Updated section "NAT"
06/02/2008	1.0.2	1) Updated section "Internet Technologies" 2) Added section "Stages in Carrying out the Regulations" 3) Updated section "Correction Functions" 4) Updated description of TDT 5) Added a table of official travel documents to DOC description 6) Corrected separator usage in UNT, UNE, UNZ segments of last edition 7) Updated section "Multi-leg Flight" 8) Added section "Wet Lease" 9) Removed section "Third-party Ground Handler"
03/14/2008	1.0.1	First release

This page is intentionally left blank.

## Contents

<b>1</b>	<b>INTRODUCTION</b>	<b>1</b>
1.1	Background.....	1
1.2	UN/EDIFACT Message Set.....	1
1.3	Type B .....	2
1.4	Internet Technologies.....	2
1.4.1	Why Web-based Application .....	2
1.4.2	Enrollment.....	3
1.4.3	Submission .....	4
1.4.4	History of Submission .....	6
1.4.5	Development Roadmap .....	6
1.5	Stages in Carrying out the Regulations .....	6
<b>2</b>	<b>MESSAGE TYPES</b>	<b>7</b>
2.1	Flight Passenger Manifest (FPM) .....	7
2.2	Flight Crew Manifest (FCM).....	7
2.3	Master Crew List (MCL) .....	7
2.4	Correction Functions .....	7
<b>3</b>	<b>DATA ITEMS</b>	<b>8</b>
3.1	Data Relating to the Flight.....	8
3.1.1	Mandatory Data Elements.....	8
3.1.2	Optional Data Elements .....	8
3.2	Data Relating to Each Passenger/Crew Member .....	8
3.2.1	Mandatory Data Elements.....	8
3.2.2	Optional Data Elements .....	9
<b>4</b>	<b>MESSAGE STRUCTURE</b>	<b>10</b>
<b>5</b>	<b>SEGMENT DESCRIPTIONS</b>	<b>11</b>
5.1	UNA: Service String Advice.....	11
5.2	UNB: Interchange Header .....	12
5.3	UNG: Group Header .....	14
5.4	UNH: Message Header .....	16
5.5	BGM: Beginning of Message.....	18

5.6	NAD: Name and Address – Reporting Party.....	19
5.7	COM: Communication Contact.....	20
5.8	TDT: Details of Transport.....	21
5.9	LOC: Place/Location Identification – Flight Itinerary .....	22
5.10	DTM: Date/Time/Period – Flight Time .....	23
5.11	NAD: Name and Address – Traveler .....	24
5.12	ATT: Attribute.....	26
5.13	DTM: Date/Time/Period – Date of Birth .....	27
5.14	LOC: Place/Location Identification – Residence/Itinerary/Birth.....	28
5.15	NAT: Nationality .....	29
5.16	RFF: Reference.....	30
5.17	DOC: Document/Message Details.....	31
5.18	DTM: Date/Time/Period – Travel Document.....	33
5.19	LOC: Place/Location Identification – Travel Document.....	34
5.20	CNT: Control Total .....	35
5.21	UNT: Message Trailer .....	36
5.22	UNE: Group Trailer .....	37
5.23	UNZ: Interchange Trailer.....	38
<b>6</b>	<b>MORE BUSINESS SCENARIOS</b>	<b>39</b>
6.1	Multi-leg Flight.....	39
6.2	Overflying Flight .....	39
6.3	Code Sharing Flight/Funnel Flight .....	39
6.4	Wet Lease.....	39
6.5	Inter Airlines Through Check-in (IATCI).....	39
	<b>APPENDIX A EXAMPLES</b>	<b>40</b>
	<b>APPENDIX B TESTING AND PRODUCTION</b>	<b>43</b>
	<b>APPENDIX C ACRONYMS AND ABBREVIATIONS</b>	<b>44</b>

# 1 Introduction

## 1.1 Background

During SARS epidemic in 2003, General Administration of Civil Aviation of China (CAAC), the Ministry of Health of the People's Republic of China (MOH), and General Administration of Quality Supervision, Inspection and Quarantine of the People's Republic of China (AQSIQ) had decided to jointly introduce Advance Passenger Information (API) with a view to effective infection control. The announcement got effective on October 26, 2003. Historically, the corresponding implementation guide supports United States Electronic Data Interchange for Administration, Commerce, and Transport (US/EDIFACT) message set.

The Airport Departure and Arrival Passenger Information System (ADAPIS) was developed to act as a gateway for air carriers to electronically transmit certain data on passengers and crew members to Chinese authorities.

Under the premise of national sovereignty and border security, the Ministry of Public Security of the People's Republic of China (MPS) and CAAC have published 'Advance Notice Implementation Regulations for Traveler Information on International Flights' (shorted as 'the Regulations' in this document) to facilitate lawful international travel. Under the Regulations, MPS/CAAC requires the advance submission of passenger and crew manifest data for certain flights operating to and from Chinese mainland.

Firstly, all passenger, cargo, and charter flights crossing Chinese mainland border, whether regular or non-regular, fall within the scope of the Regulations. That includes regional flights to and from Hong Kong, Macao, and Taiwan, whereas flights between Hong Kong, Macao, and Taiwan are not required.

Secondly, both inbound and outbound are required. Regarding outbound flights specifically, PAXLST messages should be transmitted in batch mode at present. Technical details to meet MPS prior clearance requirements will be discussed in other document.

This document is intended to be a technical guide for explaining the United Nations Electronic Data Interchange for Administration, Commerce, and Transport (UN/EDIFACT) PAXLST. In all cases, the regulations issued by Chinese authorities take priority over this document.

## 1.2 UN/EDIFACT Message Set

This document is based upon the WCO/IATA/ICAO Guidelines on API, and ISO 9735 - Electronic data interchange for administration, commerce and transport (EDIFACT) - Application level syntax rules.

After the short conversion period, support for the US/EDIFACT PAXLST has been withdrawn.

ADAPIS follows the following syntax rules:

- Only alphanumeric character, space, and special characters defined in UNA segment are permitted in PAXLST messages.
- All alpha characters are in UPPERCASE.
- If conditional elements or sub-elements are not present at the end of a segment or element, their separators can be omitted. The trailing segment terminator should never be truncated.
- The line breaks in a message have no meaning in the syntax. So a message can be transmitted either as a continuous character stream or as a human-friendly paragraph with arbitrary line breaks.

### **1.3 Type B**

MPS/CAAC receives PAXLST messages through the telecommunication network operated by SITA, in messaging traffic known as Type B.

The messages have an internal message block size of 3840 bytes, although SITA supports greater length. If a PAXLST message is larger than the block size, then each block must contain repeated service segments (refer to UNB in section 5.2 and UNZ in section 5.23), a properly structured message header and trailer (refer to UNH in section 5.4 and UNT in section 5.21), and segments relating to the flight (refer to BGM in section 5.5, TDT in section 5.8, LOC in section 5.9, DTM in section 5.10, and CNT in section 5.20).

## **1.4 Internet Technologies**

### **1.4.1 Why Web-based Application**

There should be a contingency method to submit manifest data during system failure or SITA outages. Besides the normal SITA networking, MPS/CAAC is investigating the possibility of Internet-based means by which air carriers can exchange data with governments. After a comparison of candidate solutions, including email, message queue, and web-based application, the last one stands out.

Now MPS/CAAC starts to run a website to facilitate this process. Please refer to APPENDIX B for its URL.

Here are a few thoughts of us.

- Email is not as safe and reliable as we would like it to be. And encoding types and attachments make it even harder to manage.
- Through a web-based application employees or agents worldwide all have direct access to current information.
- No special configurations or changes are needed to access a website, if exists an Internet connection.
- Software can be updated in a relatively quick and low-cost manner.

### 1.4.2 Enrollment

Registration can be accomplished online. Please be noted that user name cannot be in Chinese because it will be used in message texts later on. Once approved, an email will be sent to the user with password in it. MPS/CAAC suggests that user leave email address with corporate domain name, but not one offered by free public service.

All items here are case sensitive.

Register (Items with * must not be null. A valid email address and delegating carriers information are very important!)	
User name(*)	<input type="text" value="wanger"/>
Email(*)	<input type="text" value="api@nwa.com"/>
Real name(*)	<input type="text" value="Wang Er"/>
Company name	<input type="text" value="Northwest Airlines"/>
Fax	<input type="text" value="1 800 692 5678"/>
Tel	<input type="text" value="1 800 692 1234"/>
Delegating carriers	<input type="button" value="Select"/>
Application description	<input type="text" value="submitting manifest data in case of system outage."/>
Question for recovering password(*)	<input type="text" value="merger"/>
Answer for recovering password(*)	<input type="text" value="deltaairlines"/>
<input checked="" type="checkbox"/> I here assure above information are accurate and legal.	
<input type="button" value="Submit"/> <input type="button" value="Reset"/>	

“Delegating carriers” in the enroll form refers to a carrier list whom the user is preparing to submit manifest data for, or working with. If unduly chosen, application could be rejected, and submission could fail. Where a carrier does not own any IATA designator, “ZZ - do not have a code allocated” should be selected alternatively.

“Delegating carriers” can also be changed after approval if needed. Whereas it is such an important attribute of a user that if it was changed anytime, the account will need to be audited before it can be used again. Please provide detailed “application description” for faster approval.

“Question/answer for recovering password” is the secret token to be used when a user want to recover its password once forgotten. After providing correct information in the “lost password” page, a newly generated password will be emailed to the user.

Please be patient with the auditing process, which normally requires 24 hours.

### 1.4.3 Submission

After approval, user can login with the chosen user name and the password sent to its email address. User is encouraged to change password as soon as possible.

Here user can toggle between English and Chinese version of the user interface. This preference is saved as cookie at client side.

**Welcome to China API Portal**

User login

User name  Register? Lost password?

Password  中文 English

Now user is able to submit manifest data by typing in each data item. A user-friendly wizard interface will ease pain in generating a valid format of PAXLST messages, because system does this in the background.

As we highlighted in the user interface, “flight number and operational suffix” should not include airline IATA code. Duplicate code would cause problem.

In this form, all characters will be uppercased automatically when user submits it.

**Submission: Fill-in form**

Flight information (All items are required)	
Message type	<input type="text" value="250 - FCM"/>
Airline code	<input type="text" value="NW - Northwest Airli"/>
Flight number and operational suffix (Excluding airline IATA code)	<input type="text" value="999"/>
Departing airport	<input type="text" value="NRT"/>
Arriving airport	<input type="text" value="PEK"/>
STD (yyyy-MM-dd HH:mm:ss)	<input type="text" value="2008-01-29 18:00:00"/>
STA (yyyy-MM-dd HH:mm:ss)	<input type="text" value="2008-01-29 21:15:00"/>
Total number of travelers (3)	<input type="button" value="Go to traveler page"/>
<input type="button" value="Save as draft"/> <input type="button" value="Submit"/>	

**Submission: Fill-in form**

Traveler information (All items are required)

CLARK 1	CLARK 1			
PICARD 2	Surname	<input type="text" value="CLARK"/>	Given name	<input type="text" value="MICHAEL"/>
Traveler 3	Nationality	<input type="text" value="CAN"/>	Gender	<input type="text" value="M - Male"/>
	Birthday (yyyy-MM-dd)	<input type="text" value="1972-09-07"/>		
	Official travel document type	<input type="text" value="P - Passport"/>	Official travel document number	<input type="text" value="MB140241"/>
	Expiry date (yyyy-MM-dd)	<input type="text" value="2008-10-21"/>		
	Issuing country or organization	<input type="text" value="CAN"/>		
	Party identifier	<input type="text" value="FM - Crew"/>		
	Port of embarkation	<input type="text" value="DTW"/>	Port of debarkation	<input type="text" value="PEK"/>
				<input type="button" value="Save"/>

Of course user can also choose to submit manifest data by directly pasting message text into the web page and submit it. The message text should be a complete PAXLST, but not divided into multiple blocks.

**Submission: Raw message**

```

UNA:+. ? '
UNB+UNOA:4+NORTHWEST AIRLINES:ZZ+CNADAPIS:ZZ+080129:0900+000000000001++APIS'
UNG+PAXLST+NORTHWEST AIRLINES:ZZ+CNADAPIS:ZZ+080129:0900+1+UN+D:02B'
UNH+PAX001+PAXLST:D:02B:UN:IATA+NW0011C0801292115'
BGM+250'
NAD+MS+++WANG ER'
COM+API AT NWA.COM:EM+1 800 692 1234:TE'
TDT+20+NW11'
LOC+125+NRT'
DTM+189:0801291800:201'
LOC+87+PEK'
DTM+232:0801292115:201'
NAD+FM+++CLARK:MICHAEL'
ATT+2++M'
DTM+329:720907'
LOC+178+DTW'
LOC+179+PEK'
NAT+2+CAN'
DOC+P:110:ZZZ+MB140241'
DTM+36:081021'
    
```

ADAPIS website will provide feedback to user promptly on the processing result if any discrepancy was found. Whereas if no discrepancy was found, a string receipt will be given after the transmittal was received by ADAPIS. System automatically retains that information for your records.

Please be noted that ADAPIS checks format validity of the transmittals and nothing beyond. This means even ADAPIS accepts them, there is a possibility of violation regarding timeliness, completeness, and correctness of the transmittals found at the immigration front line correspondingly.

#### 1.4.4 History of Submission

User can get a list of successful submission of its self online. This is confined to the information submitted through here the website.

Submission: My web submission				
	Submission time	User name	Receipt	
1	2008-01-29 19:00:00	guest	3D80BF88DE9941CD804E8660688B6537	Show

Latest submission comes first in the list.

#### 1.4.5 Development Roadmap

The following features will be added in future releases of the website.

- Start to submit manifest data by modifying a former submission. This is especially useful for some carriers to submit FCM, and when you want to change an incorrect submission.
- Query history of successful submission, whether via SITA network or via Internet.
- Query history of failed submission, which reached ADAPIS via SITA network.

Some features above may not appear in function list of basic level user.

### 1.5 Stages in Carrying out the Regulations

As air carriers should take time to update and test their systems, train their employees, the regulations are implemented in several stages.

- Stage I (May 1, 2008 – May 31, 2008): MPS/CAAC checks format validity and evaluates timeliness of transmittal, and imposes mitigated punishment based on the particular circumstances.
- Stage II (June 1, 2008 – June 30, 2008): Besides above, MPS/CAAC checks completeness of mandatory data items, and continues to adopt mitigated punishment strategy.
- Stage III (From July 1, 2008 on): MPS/CAAC checks validity, timeliness, completeness, and correctness of the manifest data, and measure penalty as normal.

## **2 Message Types**

### **2.1 Flight Passenger Manifest (FPM)**

FPM refers to passenger (including infant and child) manifest data to be submitted to Chinese authorities.

### **2.2 Flight Crew Manifest (FCM)**

FCM refers to crew (including cockpit, cabin, airline operation, non-crew, and deadhead) manifest data to be submitted to Chinese authorities.

Unless otherwise noted, 'crew' also refers to 'non-crew'.

Non-crew members are defined as air carrier employees and their family members and persons travelling onboard an all-cargo aircraft for the safety of the flight (such as an animal handler when animals are onboard). These travelers on passenger or dual flights are considered passengers.

### **2.3 Master Crew List (MCL)**

Not required.

### **2.4 Correction Functions**

Air carriers who wish to make a correction or addition to some parts of the manifest data that has already been submitted to MPS/CAAC should do so by re-transmitting the whole FPM or FCM after making necessary corrections or additions. The former manifest data and certain vetting data for the corresponding FPM or FCM will be deleted entirely. Do not use BGM data element 1004 to identify message type.

ADAPIS uses following keys to identify an FPM or FCM:

- IATA airline code
- Flight number
- Operational suffix (if exists)
- Movement indicator (inbound/outbound)
- Scheduled operating time at Chinese mainland airport

## **3 Data Items**

### **3.1 Data Relating to the Flight**

#### **3.1.1 Mandatory Data Elements**

IATA airline code, flight number, and operational suffix (if exists)

Last airport before arriving Chinese mainland (only for inbound)

First airport after arriving Chinese mainland (only for inbound)

Last airport before departing Chinese mainland (only for outbound)

First airport after departing Chinese mainland (only for outbound)

STD (optional for end airport)

STA (optional for start airport)

Number of passengers/crew members on the flight

#### **3.1.2 Optional Data Elements**

### **3.2 Data Relating to Each Passenger/Crew Member**

#### **3.2.1 Mandatory Data Elements**

Name (surname, given name)

Nationality

Gender

Date of birth

Official travel document type

Official travel document number

Expiration date of the official travel document

Issuing country or organization of the official travel document

Party identifier (passenger, crew, in-transit passenger, in-transit crew)

Port of embarkation

Port of debarkation

### **3.2.2 Optional Data Elements**

Destination address

Port of clearance (only for inbound)

Country of primary residence

Country of birth

PNR reference

Other document type

Other document number

Expiration date of the other travel document

Issuing date of the other travel document

Issuing country or organization of the other travel document

## 4 Message Structure

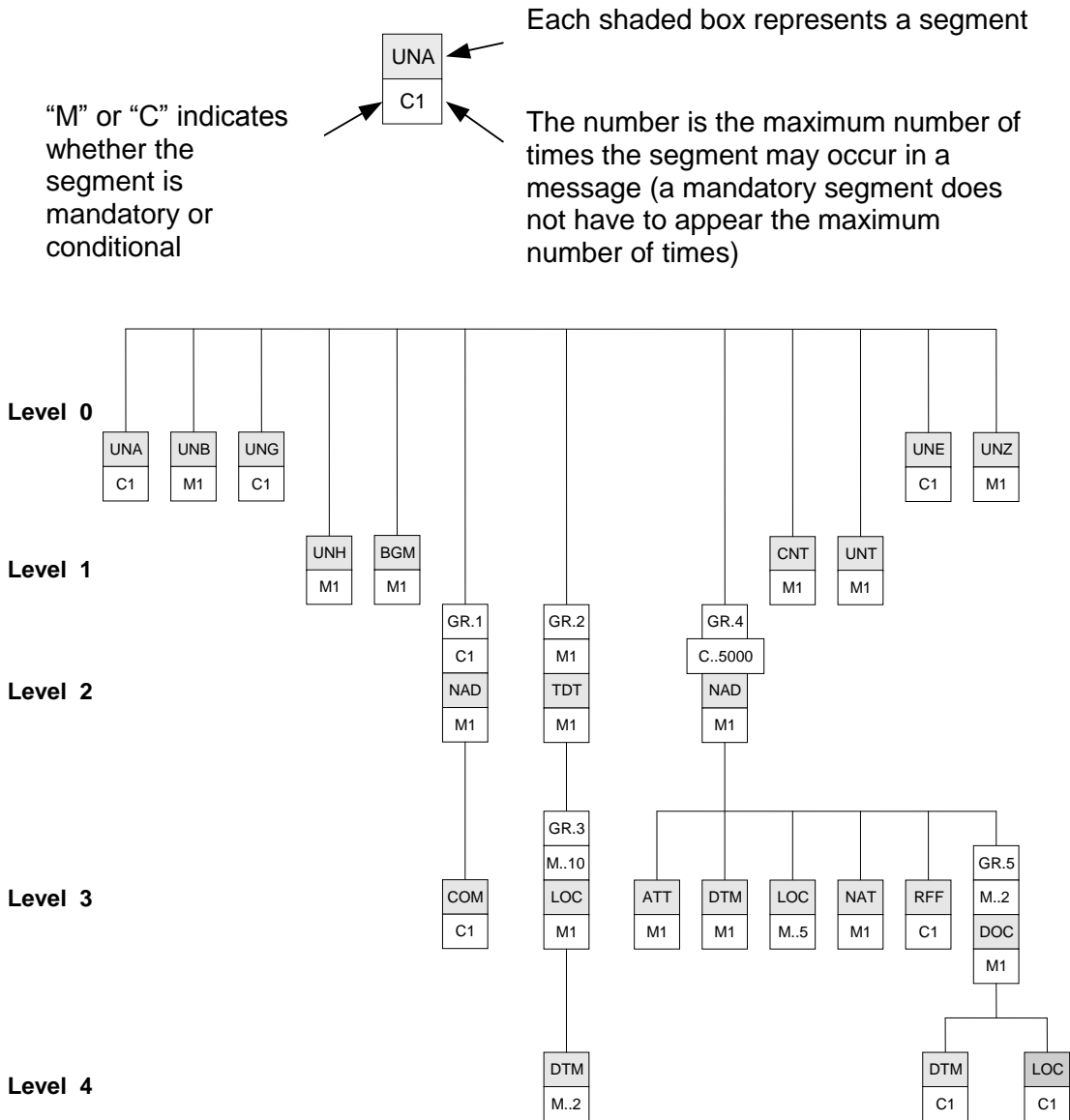

Note: The groups and segments must be organized in the same order as shown above. Or the whole transmission might be considered illegal and discarded.

## 5 Segment Descriptions

### 5.1 UNA: Service String Advice

Function: To define characters used as separators and indicators. If used, this segment must be the first segment in the message, before the UNB segment.

Usage: Conditional

Example: UNA:+.? ‘

<b>UNA</b>	<b>: (colon)</b> Sub-element Separator	<b>+ (plus sign)</b> Element Separator	<b>. (period)</b> Decimal Notation
	<b>? (question mark)</b> Release Indicator	<b>(space)</b> Reserved for Future Use	<b>‘ (single quote)</b> Segment Terminator

Note:

- 1) If the UNA segment is not present, the values shown here will be used as defaults.
- 2) The release indicator (or escape character) immediately preceding a special character (sub-element separator, element separator, release indicator, segment terminator) restores its normal meaning. Space in elements does not have to be preceded with a release indicator.
- 3) A space must not be used as a separator or other formatting indicator. The exception is the fifth character, because this character has no function in this implementation.

## 5.2 UNB: Interchange Header

Function: To identify an interchange and identify the syntax.

Usage: Mandatory

Example: UNB+UNOA:4+NORTHWEST AIRLINES:ZZ+CNADAPIS:ZZ+080129:0900+000000000001++APIS'

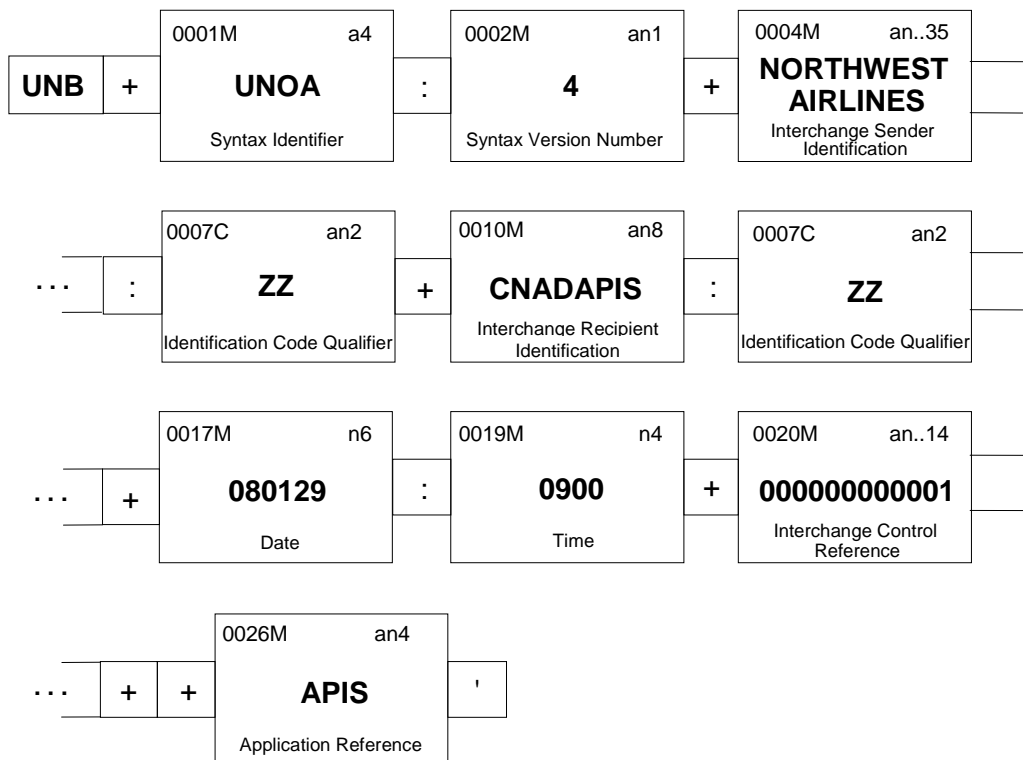

Definition:

Element	Name	Format	Notes
	Segment Label		<b>UNB</b>
0001	Syntax Identifier	a4	Always <b>UNOA</b>
0002	Syntax Version Number	an1	Always <b>4</b>
0004	Interchange Sender Identification	an..35	Carrier name or identification of the sender if other party other than the carrier itself sends this message
0007	Identification Code Qualifier	an2	Any value
0010	Interchange Recipient Identification	an8	Always <b>CNADAPIS</b>
0007	Identification Code Qualifier	an2	Always <b>ZZ</b> , if present
0017	Date	n6	Local date of message preparation as RRMDD

The Ministry of Public Security of the People's Republic of China

Civil Aviation Administration of China

---

0019	Time	n4	Local time of day of message preparation as HH24MI
0020	Interchange Control Reference	an..14	Any value
0026	Application Reference	an4	Always <b>APIS</b>

---

### 5.3 UNG: Group Header

Function: To specify a group of messages. Only one group of messages is allowed in this application.

Usage: Conditional

Example: UNG+PAXLST+NORTHWEST AIRLINES:ZZ+CNADAPIS:ZZ+080129:0900+1+UN+D:02B'

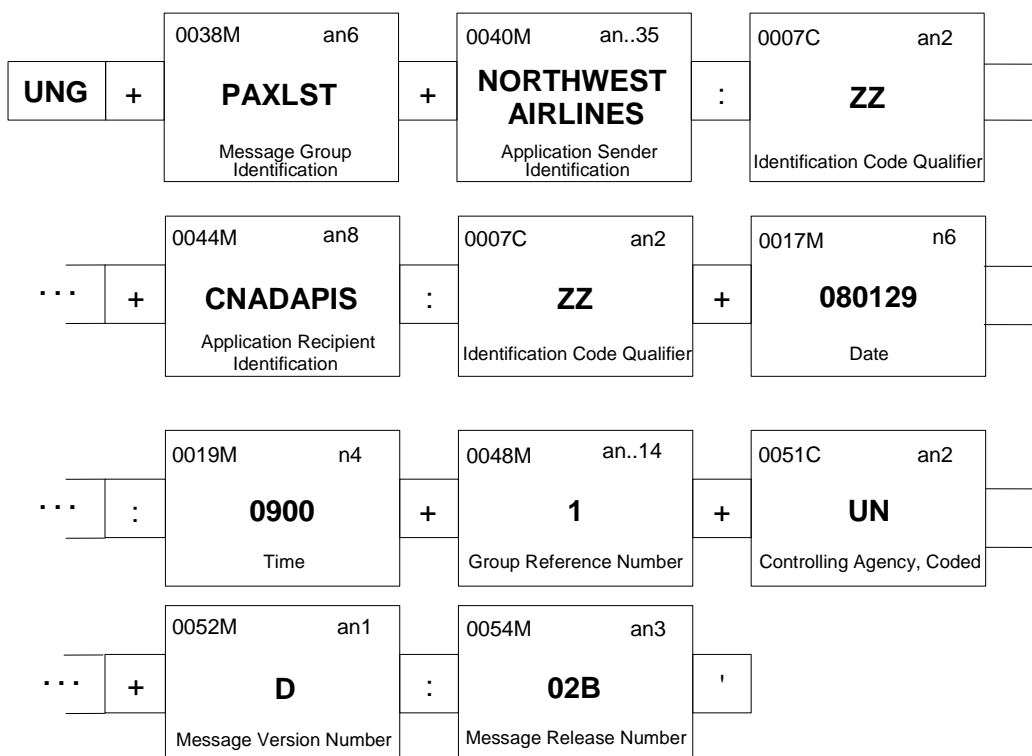

Definition:

Element	Name	Format	Notes
	Segment Label		<b>UNG</b>
0038	Message Group Identification	an6	Always <b>PAXLST</b>
0040	Application Sender Identification	an..35	Carrier name
0007	Identification Code Qualifier	an2	Any value
0044	Application Recipient Identification	an8	Always <b>CNADAPIS</b>
0007	Identification Code Qualifier	an2	Always <b>ZZ</b> , if present
0017	Date	n6	Local date of message preparation as RRMDD
0019	Time	n4	Local time of day of message preparation as HH24MI
0048	Group Reference Number	an..14	Any value
0051	Controlling Agency Code	an2	Always <b>UN</b>
0052	Message Version Number	an1	Always <b>D</b>
0054	Message Release Number	an3	Always <b>02B</b>

Note:

- 1) A carrier who sends the message itself does not need the UNG/UNE.
- 2) If another party sends the message on behalf of the carrier, then the UNG segment should be present.

## 5.4 UNH: Message Header

Function: To identify and specify the PAXLST message.

Usage: Mandatory

Example: UNH+PAX001+PAXLST:D:02B:UN:IATA+NW00110801292115+01:F'

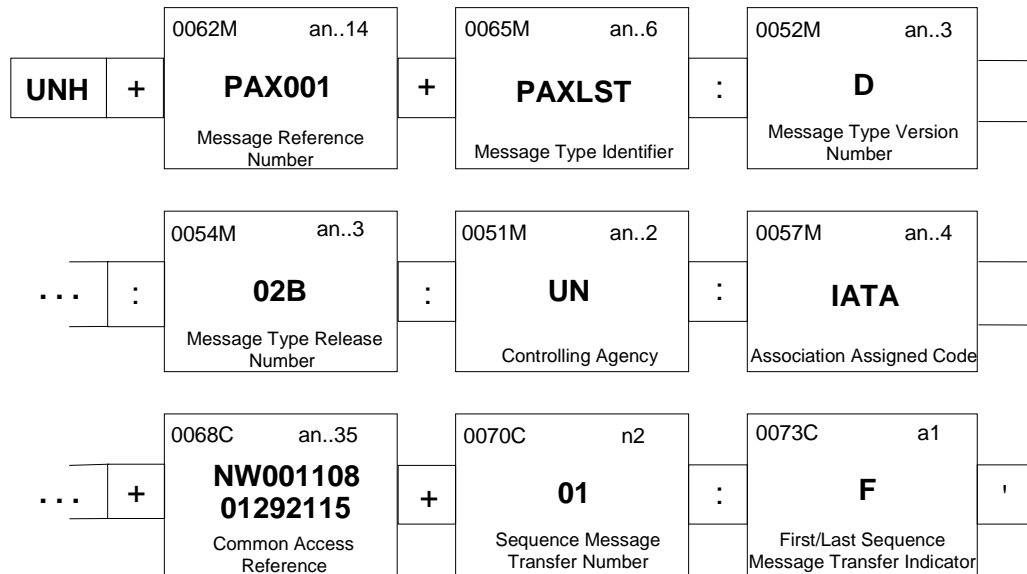

Definition:

Element	Name	Format	Notes
	Segment Label		<b>UNH</b>
0062	Message Reference Number	an..14	Any value
0065	Message Type Identifier	an..6	Always <b>PAXLST</b>
0052	Message Type Version Number	an..3	Always <b>D</b>
0054	Message Type Release Number	an..3	Always <b>02B</b>
0051	Controlling Agency	an2	Always <b>UN</b>
0057	Association Assigned Code	an..4	Always <b>IATA</b>
0068	Common Access Reference	an..35	Unique value assigned to the message
0070	Sequence Message Transfer Number	n2	Required for a multi-block message, to number each block. The first block number is '01', and increases by 1 for each block. For a single-block message, use '01' or omit it
0073	First/Last Sequence Message Transfer Indicator	a1	Use 'C' for first block. Use 'F' for final block. Omit it for intermediate blocks. For a

The Ministry of Public Security of the People's Republic of China

Civil Aviation Administration of China

---

---

single-block message, use 'F' or  
omit it

---

Note: ADAPIS uses element 0068 as a key to join multiple blocks. It is necessary to set different values for each message, even for the FPM and FCM of a single flight.

## 5.5 BGM: Beginning of Message

Function: To indicate whether the PAXLST message is a passenger or crew list message.

Usage: Mandatory

Example: BGM+745'

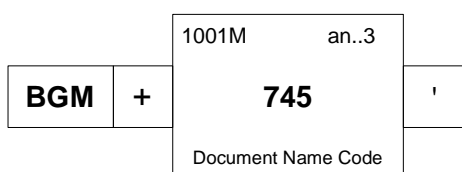

Definition:

Element	Name	Format	Notes
	Segment Label		<b>BGM</b>
1001	Document Name Code	an..3	Values are: <b>250</b> for FCM <b>745</b> for FPM

---

## 5.6 NAD: Name and Address – Reporting Party

Function: To specify a contact responsible for the message content.

Usage: Conditional

Example: NAD+MS+++WANG ER'

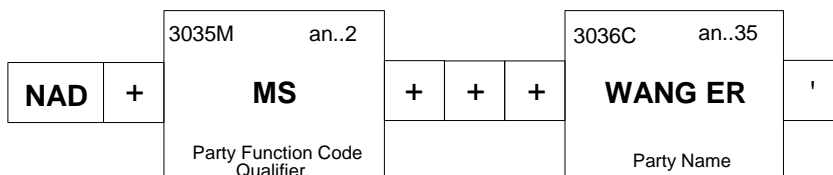

Definition:

Element	Name	Format	Notes
	Segment Label		<b>NAD</b>
3035	Party Function Code Qualifier	an..2	Always <b>MS</b>
3036	Party Name	an..35	Name of a responsible party for the manifest data

## 5.7 COM: Communication Contact

Function: To specify the communication number(s) of the person responsible for the message content.

Usage: Conditional

Example: COM+API AT NWA.COM:EM+1 800 692 1234:TE'

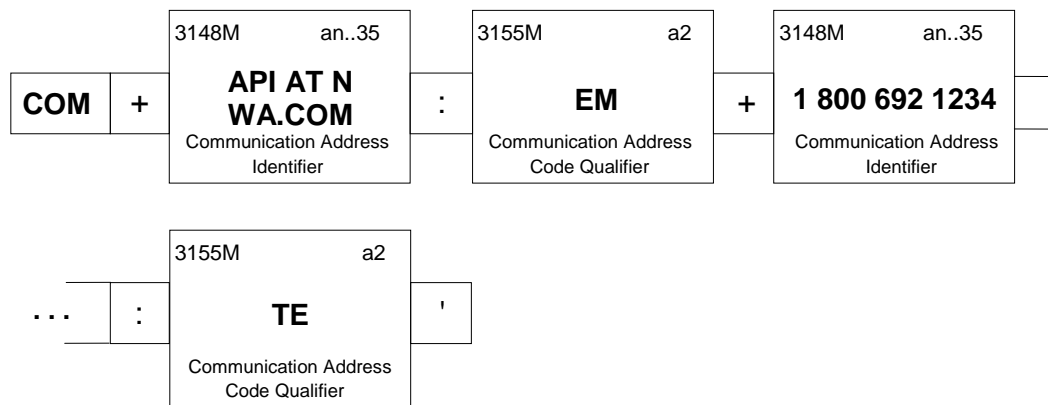

Definition:

Element	Name	Format	Notes
	Segment Label		<b>COM</b>
3148	Communication Identifier	an..35	Email address, fax number, or telephone number of reporting party
3155	Communication Code Qualifier	a2	Values are: <b>EM</b> for electronic mail <b>FX</b> for telefax <b>TE</b> for telephone

Note:

- 1) Elements 3148 and 3155 can be present up to three times to provide different points of contact.
- 2) '@' (at sign) is not permitted in electronic mail element. Use ' AT ' (space, AT, and another space) in turn.
- 3) '-' (hyphen) is not permitted in telefax and telephone element. Use space in turn.

## 5.8 TDT: Details of Transport

Function: To identify the flight by IATA airline designator and flight number.

Usage: Mandatory

Example: TDT+20+NW11’

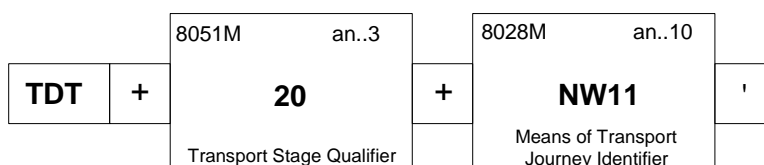

Definition:

Element	Name	Format	Notes
	Segment Label		<b>TDT</b>
8051	Transport Stage Qualifier	an..3	Always <b>20</b>
8028	Journey Identifier	an..10	A concatenation of the: 1. Airline code, in IATA an2 format 2. Flight number, in n..4 format 3. Operational suffix, in an..2 format or 1. Airline code, in IATA an2 format 2. Tail number, in an..8 format alternatively for a non-regular flight without flight number

Note:

- 1) Carrier without an IATA designator uses 'ZZ'.
- 2) The 'C' suffix for FCM defined in US/EDIFACT should not be sent.

### 5.9 LOC: Place/Location Identification – Flight Itinerary

Function: To identify the arrival and departure airports relating to the specified flight.

Usage: Mandatory

Example: LOC+125+NRT'

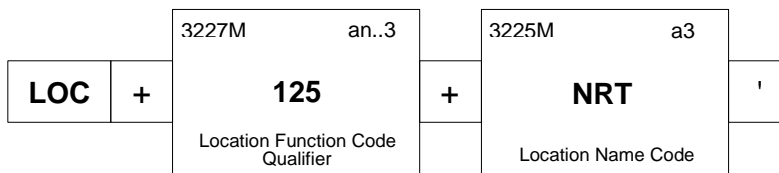

Definition:

Element	Name	Format	Notes
	Segment Label		<b>LOC</b>
3227	Location Function Code Qualifier	an..3	Values are: <b>87</b> for first airport after arriving Chinese mainland (inbound), or for first airport after departing Chinese mainland (outbound) <b>125</b> for last airport before arriving Chinese mainland (inbound), or for last airport before departing Chinese mainland (outbound)
3225	Location name Code	a3	IATA airport code

Note: Two and only two LOC segments are required. Airports on other flight legs should not be reported.

### 5.10 DTM: Date/Time/Period – Flight Time

Function: To specify the departure and arrival dates/times for a flight.

Usage: Mandatory

Example: DTM+189:0801291800:201'

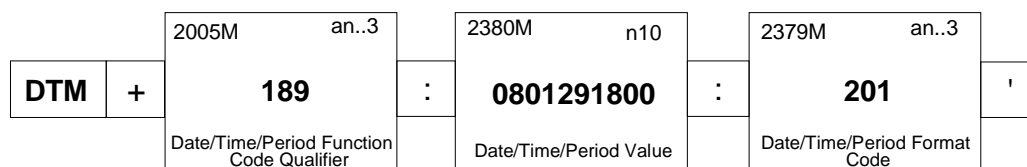

Definition:

Element	Name	Format	Notes
	Segment Label		<b>DTM</b>
2005	Date/Time Period Function Code Qualifier	an..3	Values are: <b>189</b> for STD <b>232</b> for STA
2380	Date/Time Period Value	n10	Local time in format RRMMDDHH24MI
2379	Date/Time Period Format Code	an..3	Always <b>201</b>

### 5.11 NAD: Name and Address – Traveler

Function: To specify the name and address of a passenger or crew member aboard a specified flight.

Usage: Mandatory

Example: NAD+FL+++WILLIAMS:JOHN DONALD+1 EAST CHANGAN AVENUE+DONGCHENG DISTRICT+BEIJING+100738+CHN'

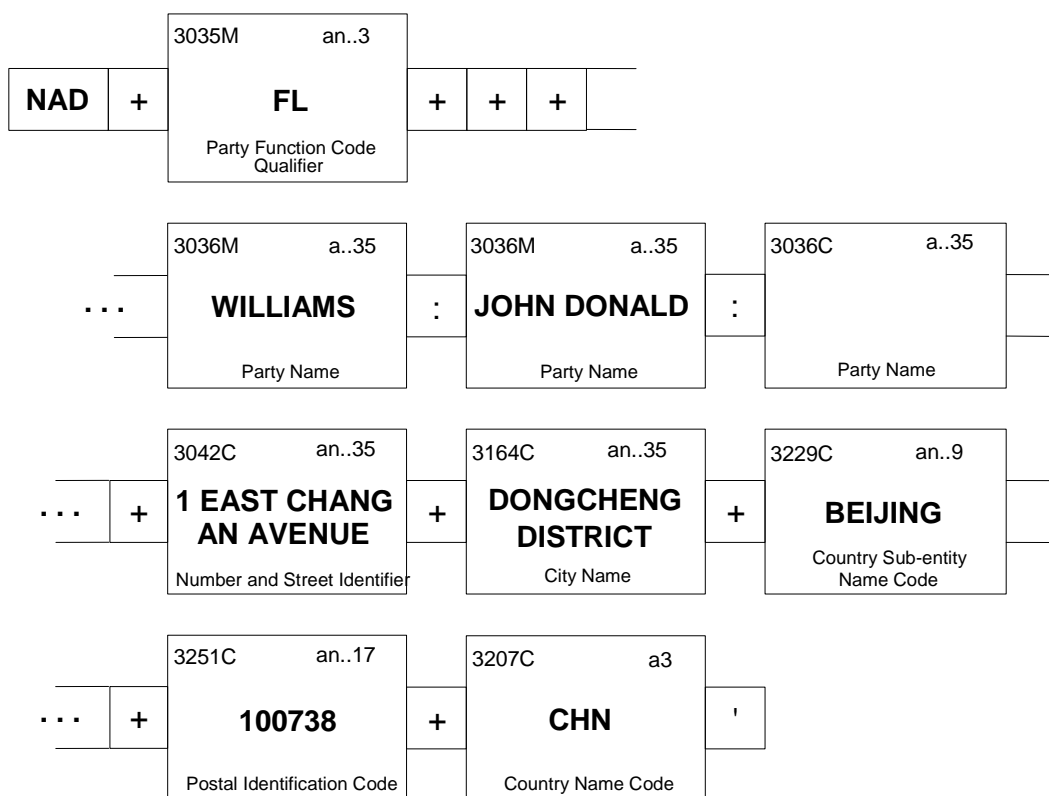



### 5.12 ATT: Attribute

Function: To identify the gender of the passenger or crew member.

Usage: Mandatory

Example: ATT+2++M'

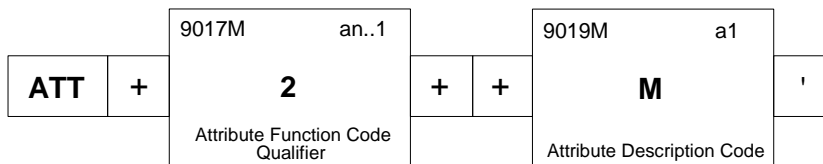

Definition:

Element	Name	Format	Notes
	Segment Label		<b>ATT</b>
9017	Attribute Function Code Qualifier	an..1	Always <b>2</b>
9019	Attribute Description Code	a1	Values are: <b>F</b> for female <b>M</b> for male <b>U</b> for unknown

### 5.13 DTM: Date/Time/Period – Date of Birth

Function: To specify the date of birth of a passenger or crew member.

Usage: Mandatory

Example: DTM+329:640217'

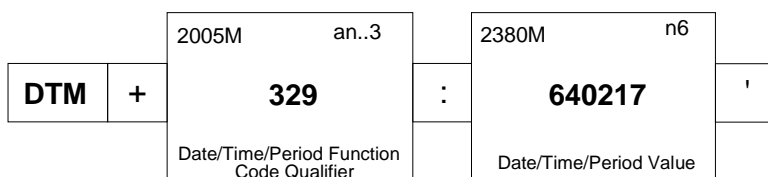

Definition:

Element	Name	Format	Notes
	Segment Label		<b>DTM</b>
2005	Date/Time/Period Function Code Qualifier	an..3	Always <b>329</b>
2380	Date/Time/Period Value	n6	Date of birth in format RRMMDD

### 5.14 LOC: Place/Location Identification – Residence/Itinerary/Birth

Function: To identify the country of residence, the airports related to the journey, and the place of birth of a passenger or crew member.

Usage: Mandatory

Example: LOC+178+DTW'

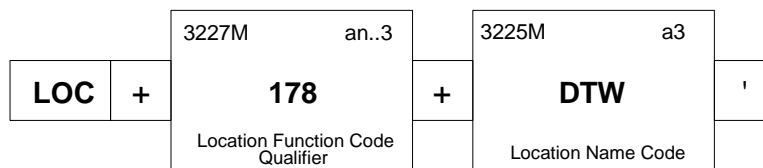

Definition:

Element	Name	Format	Notes
	Segment Label		<b>LOC</b>
3227	Location Function Code Qualifier	an..3	Values are: <b>22</b> for airport where traveler completes clearance procedures <b>174</b> for country of primary residence <b>178</b> for earliest known airport where traveler begins the journey, which may be different from the flight’s departure airport <b>179</b> for final known airport where traveler ends the journey, which may be different from the flight’s arrival airport <b>180</b> for country of birth
3225	Location name Code	a3	IATA airport code

Note:

- 1) The itinerary of each individual traveler is required, even if it matches the flight itinerary. ADAPIS does not extract the missing itinerary from the flight itinerary.
- 2) Qualifiers 22, 174, and 180 are optional.

### 5.15 NAT: Nationality

Function: To specify the nationality of a passenger or crew member.

Usage: Mandatory

Example: NAT+2+CAN'

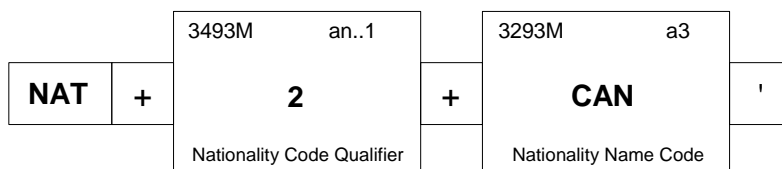

Definition:

Element	Name	Format	Notes
	Segment Label		<b>NAT</b>
3493	Nationality Code Qualifier	an..1	Always <b>2</b>
3293	Nationality Name Code	a3	ISO 3166-1 alpha-3 country code

### 5.16 RFF: Reference

Function: To specify the passenger reservation reference number.

Usage: Conditional

Example: RFF+AVF:WWHPDS'

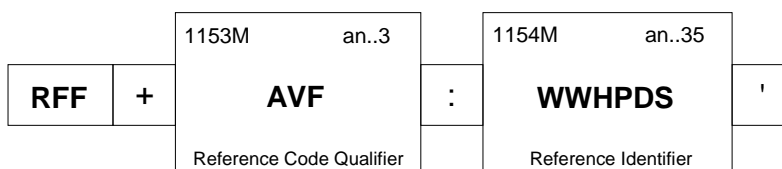

Definition:

Element	Name	Format	Notes
	Segment Label		<b>RFF</b>
1153	Reference Code Qualifier	an3	Always <b>AVF</b>
1154	Reference Identifier	an..35	Passenger reservation reference number

Note:

- 1) This segment does not apply to crew members.
- 2) If a carrier does not employ a passenger record locator system, it is not necessary to develop one for manifest data submission.

### 5.17 DOC: Document/Message Details

Function: To identify the official travel document and/or other document used for travel.

Usage: Mandatory

Example: DOC+P:110:ZZZ+98764312'

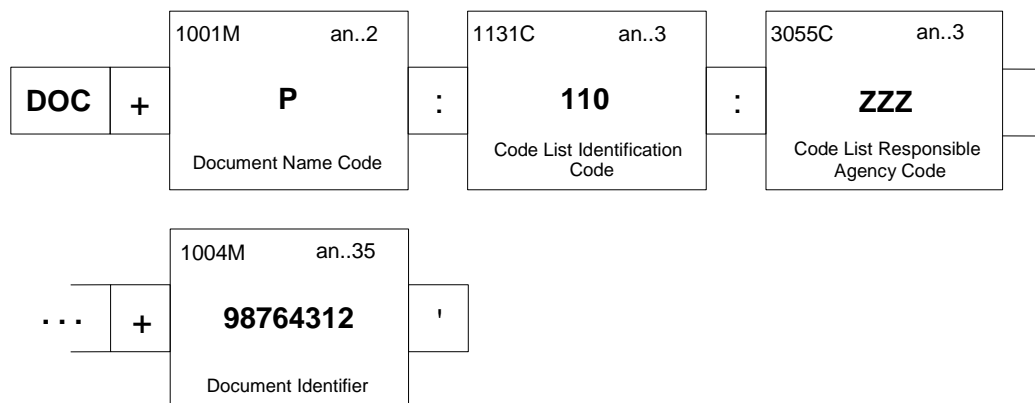

Definition:

Element	Name	Format	Notes
	Segment Label		<b>DOC</b>
1001	Document Name Code	an..2	1. Official travel documents: Find next page for a comprehensive list of them 2. Other documents: <b>V</b> for Visa <b>AC</b> for Crew Member Certificate
1131	Code List Identification Code	an..3	Always <b>110</b> , if present
3055	Code List Responsible Agency Code	an..3	Always <b>ZZZ</b> , if present
1004	Document Identifier	an..35	Unique number assigned to the document

Note:

- 1) Non-ICAO 9303 codes may also use element 1131 and 3055.
- 2) Visa and Crew Member Certificate are optional.
- 3) Document information can be collected either from MRZ or VIZ for MRTDs. This means both are correct when what is shown in MRZ is different from that in VIZ.

Official Travel Documents

Code	Name	名称	MRTD	Expiry Date	Issue Country / Organization
P	Passport	护照	N/A	Yes	Yes
PT	P.R. China Travel Permit	中华人民共和国旅行证	Yes	Yes	Always CHN
PL	P.R. China Exit and Entry Permit	中华人民共和国出入境通行证	N/A	Yes	Always CHN
W	Travel Permit To and From HK and Macao	往来港澳通行证	Yes	Yes	Always CHN
A	Travel Permit To and From HK and Macao for Public Affairs	因公往来香港澳门特别行政区通行证	Yes	Yes	Always CHN
Q	Travel Permit To HK and Macao	前往港澳通行证	Yes	Yes	Always CHN
C	Travel Permit of HK and Macao Residents To and From Mainland	港澳同胞回乡证、港澳居民来往内地通行证	Yes	Yes	Always CHN
D	Travel Permit of Mainland Residents To and From Taiwan	大陆居民往来台湾通行证	Yes	Yes	Always CHN
T	Travel Permit of Taiwan Residents To and From Mainland	台湾居民来往大陆通行证	Yes	Yes	Always CHN
S	Seafarer's Passport	海员证	N/A	Yes	Yes
F	Approved non-standard identity documents used for travel	其他证件	N/A	N/A	Yes

Note:

- 1) Hong Kong Special Administrative Region Passport / Macao Special Administrative Region Passport can be a choice for Hong Kong / Macao residents who are in transit at mainland airport.
- 2) Taiwan ID Card is used for Taiwan resident who will obtain document after landing, if applicable.
- 3) Resident Identity Card of P.R. China is used for mainland resident who lost document in Taiwan.

### 5.18 DTM: Date/Time/Period – Travel Document

Function: To specify the expiry date of the official document or the issue date of the other document used to travel.

Usage: Conditional (required for official document)

Example: DTM+36:081215'

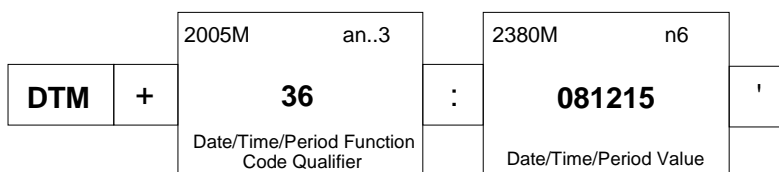

Definition:

Element	Name	Format	Notes
	Segment Label		<b>DTM</b>
2005	Date/Time/Period Function Code Qualifier	an..3	Values are: <b>36</b> for expiry date <b>182</b> for issue date
2380	Date/Time/Period Value	n6	Date in format RRMMDD, or <b>991231</b> for permanent travel document

### 5.19 LOC: Place/Location Identification – Travel Document

Function: To identify either the country of issue of the official travel document or the place of issue of the other document used for travel.

Usage: Conditional (required for official document)

Example: LOC+91+CAN'

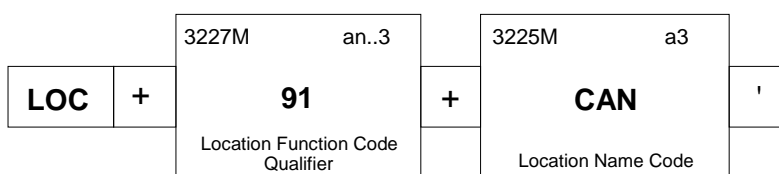

Definition:

Element	Name	Format	Notes
	Segment Label		<b>LOC</b>
3227	Location Function Code Qualifier	an..3	Always <b>91</b>
3225	Location Name Code	a3	ISO 3166-1 alpha-3 country code, or <b>UNA</b> for United Nations Specialized Agency Official <b>UNO</b> for United Nations Official

## 5.20 CNT: Control Total

Function: To provide message control total.

Usage: Mandatory

Example: CNT+42:160'

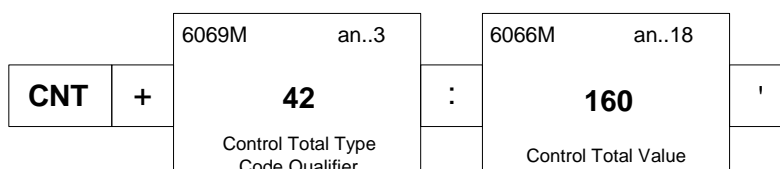

Definition:

Element	Name	Format	Notes
	Segment Label		<b>CNT</b>
6069	Control Total Type Code Qualifier	an..3	Values are: <b>41</b> for total number of crew members <b>42</b> for total number of passengers
6066	Control Total Value	an..18	Total number of travelers of this type

Note: This value should be the total number of travelers on a specific flight, but not the number of travelers in the enclosing block or transmission.

## 5.21 UNT: Message Trailer

Function: To end and check the completeness of a message by counting the segments in the message and validating the message.

Usage: Mandatory

Example: UNT+21+PAX001’

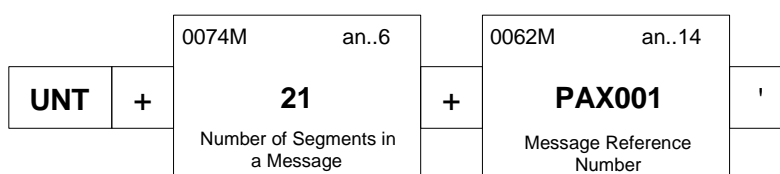

Definition:

Element	Name	Format	Notes
	Segment Label		<b>UNT</b>
0074	Number of Segments in a Message	an..6	Number of segments from UNH to this segment, inclusive
0062	Message Reference Number	an..14	Must be identical to UNH data element 0062

## 5.22 UNE: Group Trailer

Function: To terminate a message group.

Usage: Conditional

Example: UNE+1+1'

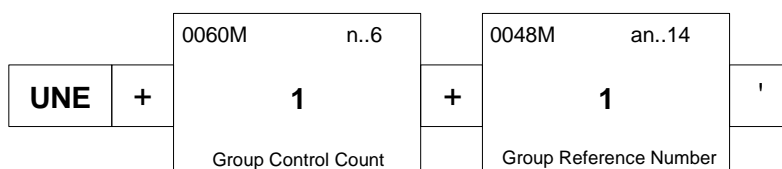

Definition:

Element	Name	Format	Notes
	Segment Label		<b>UNE</b>
0060	Group Control Count	n..6	Number of messages in the group. Usually have the value 1; It will be 2 if both crew and passenger manifest are included
0048	Group Reference Number	an..14	Must be identical to UNG data element 0048

Note: UNE presents if the UNG segment is present.

### 5.23 UNZ: Interchange Trailer

Function: To terminate an interchange and provide a check on completeness.

Usage: Mandatory

Example: UNZ+1+000000000001'

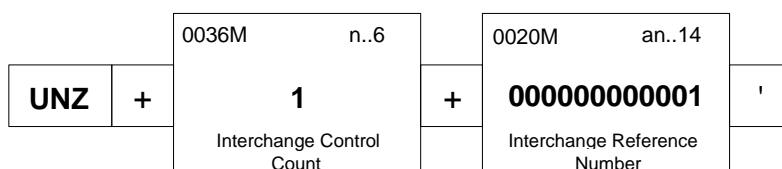

Definition:

Element	Name	Format	Notes
	Segment Label		<b>UNZ</b>
0036	Interchange Control Count	n..6	Always <b>1</b>
0020	Interchange Reference Number	an..14	Must be identical to UNB data element 0020

## **6 More Business Scenarios**

### **6.1 Multi-leg Flight**

According to the Regulations, only the flight leg that crosses the Chinese mainland border needs to be reported. Domestic continuance flight legs and foreign flight legs are not required.

The PAXLST reported for the flight leg should include all passengers/crew members who are flying over Chinese mainland border. As some carriers use different DCSs to process passengers at each airport, they intend to submit manifest data separately. It should be noted that the overwriting mechanism is very important for correction functions. ADAPIS cannot merge messages arbitrarily. MPS/CAAC advises carrier to set up a transmission channel among systems of carrier itself.

Flight transits through Chinese mainland should be reported as both an inbound flight and an outbound flight.

### **6.2 Overflying Flight**

Not required.

### **6.3 Code Sharing Flight/Funnel Flight**

The operating carrier submits manifest data. The marketing carrier is exempt.

The message should not use the marketing airline code and flight number.

### **6.4 Wet Lease**

The lessee, which is the carrier, submits manifest data. Anyhow, there is an option that the lesser submits FCM and the lessee submits FPM under bilateral agreement.

ADAPIS does not require FPM and FCM to be sent from same SITA address or same account at ADAPIS website.

### **6.5 Inter Airlines Through Check-in (IATCI)**

The carrier who operates the cross-border flight must submit manifest data without exception.

MPS/CAAC recognises that some airline partners implement IATCI with an EDIFACT protocol version 03:1, while some other use version 94:1. Since only version 03:1 supports manifest data exchange. The old implementation demands an update.

## APPENDIX A Examples

Single-block FCM, with 2 crew members:

```
UNA:+.? '  
UNB+UNOA:4+NORTHWEST AIRLINES:ZZ+CNADAPIS:ZZ+080129:0900+00000  
0000001++APIS '  
UNG+PAXLST+NORTHWEST AIRLINES:ZZ+CNADAPIS:ZZ+080129:0900+1+UN+  
D:02B '  
UNH+PAX001+PAXLST:D:02B:UN:IATA+NW0011C0801292115 '  
BGM+250 '  
NAD+MS+++WANG ER '  
COM+API AT NWA.COM:EM+1 800 692 1234:TE '  
TDT+20+NW11 '  
LOC+125+NRT '  
DTM+189:0801291800:201 '  
LOC+87+PEK '  
DTM+232:0801292115:201 '  
NAD+FM+++CLARK:MICHAEL '  
ATT+2++M '  
DTM+329:720907 '  
LOC+178+DTW '  
LOC+179+PEK '  
NAT+2+CAN '  
DOC+P:110:ZZZ+MB140241 '  
DTM+36:081021 '  
LOC+91+CAN '  
NAD+FM+++PICARD:JAVERT A '  
ATT+2++M '  
DTM+329:620907 '  
LOC+178+DTW '  
LOC+179+PEK '  
NAT+2+FRA '  
DOC+P:110:ZZZ+123498701 '  
DTM+36:091021 '  
LOC+91+FRA '  
CNT+41:2 '  
UNT+29+PAX001 '  
UNE+1+1 '  
UNZ+1+0000000000001 '
```

Multi-block FPM, with 3 passengers:

```
UNA:+.? '  
UNB+UNOA:4+NORTHWEST AIRLINES:ZZ+CNADAPIS:ZZ+080129:0900+00000  
0000001++APIS '  
UNG+PAXLST+NORTHWEST AIRLINES:ZZ+CNADAPIS:ZZ+080129:0900+1+UN+  
D:02B '  
UNH+PAX001+PAXLST:D:02B:UN:IATA+NW00110801292115+01:C '  
BGM+745 '  
NAD+MS+++WANG ER '  
COM+API AT NWA.COM:EM+1 800 692 1234:TE '
```

The Ministry of Public Security of the People's Republic of China

Civil Aviation Administration of China

---

TDT+20+NW11 '  
LOC+125+NRT '  
DTM+189:0801291800:201 '  
LOC+87+PEK '  
DTM+232:0801292115:201 '  
NAD+FL+++WILLIAMS:JOHN DONALD '  
ATT+2++M '  
DTM+329:640217 '  
LOC+178+NRT '  
LOC+179+PEK '  
NAT+2+CAN '  
RFF+AVF:WWHPDS '  
DOC+P:110:ZZZ+98764312 '  
DTM+36:081215 '  
LOC+91+CAN '  
CNT+42:3 '  
UNT+21+PAX001 '  
UNE+1+1 '  
UNZ+1+000000000001 '

UNA:+.? '  
UNB+UNOA:4+NORTHWEST AIRLINES:ZZ+CNADAPIS:ZZ+080129:0900+00000  
0000001++APIS '  
UNG+PAXLST+NORTHWEST AIRLINES:ZZ+CNADAPIS:ZZ+080129:0900+1+UN+  
D:02B '  
UNH+PAX001+PAXLST:D:02B:UN:IATA+NW00110801292115+02 '  
BGM+745 '  
NAD+MS+++WANG ER '  
COM+API AT NWA.COM:EM+1 800 692 1234:TE '  
TDT+20+NW11 '  
LOC+125+NRT '  
DTM+189:0801291800:201 '  
LOC+87+PEK '  
DTM+232:0801292115:201 '  
NAD+FL+++PORIZKOVA:ELISABETH '  
ATT+2++F '  
DTM+329:720623 '  
LOC+178+NRT '  
LOC+179+PEK '  
NAT+2+CZE '  
RFF+AVF:2HHYUI '  
DOC+P:110:ZZZ+564SBB415 '  
DTM+36:081210 '  
LOC+91+CZE '  
CNT+42:3 '  
UNT+21+PAX001 '  
UNE+1+1 '  
UNZ+1+000000000001 '

UNA:+.? '  
UNB+UNOA:4+NORTHWEST AIRLINES:ZZ+CNADAPIS:ZZ+080129:0900+00000  
0000001++APIS '

The Ministry of Public Security of the People's Republic of China

Civil Aviation Administration of China

---

UNG+PAXLST+NORTHWEST AIRLINES:ZZ+CNADAPIS:ZZ+080129:0900+1+UN+  
D:02B'  
UNH+PAX001+PAXLST:D:02B:UN:IATA+NW00110801292115+03:F'  
BGM+745'  
NAD+MS+++WANG ER'  
COM+API AT NWA.COM:EM+1 800 692 1234:TE'  
TDT+20+NW11'  
LOC+125+NRT'  
DTM+189:0801291800:201'  
LOC+87+PEK'  
DTM+232:0801292115:201'  
NAD+FL+++EWING:JAMES'  
ATT+2++M'  
DTM+329:670517'  
LOC+178+NRT'  
LOC+179+PEK'  
NAT+2+USA'  
RFF+AVF:YZPW44'  
DOC+P:110:ZZZ+XY426241'  
DTM+36:081021'  
LOC+91+USA'  
CNT+42:3'  
UNT+21+PAX001'  
UNE+1+1'  
UNZ+1+000000000001'

## **APPENDIX B    Testing and Production**

For those air carriers concerned, the SITA production and testing address is both as follows:

PEKKN1E

Conversion from US/EDIFACT to UN/EDIFACT will require a modification to a participating carrier's system, and may introduce problems. Therefore, air carriers must notify MPS/CAAC through email and get authorized to test. Please include the following information in the email: source address, proposed time for testing, flight number, operating time, and message type. Then we can trace it and check its validity.

On the other hand, for those who choose the way of Internet, the website locates at:

<http://adapis.travelsky.com/>

MPS/CAAC contact information:

[api@travelsky.com](mailto:api@travelsky.com)

Note that this email address is not a destination of 'live' PAXLST messages. Please don't send them to it.

## **APPENDIX C    Acronyms and Abbreviations**

CAAC:	Civil Aviation Administration of China
MOH:	The Ministry of Health of the People's Republic of China
AQSIQ:	General Administration of Quality Supervision, Inspection and Quarantine of the People's Republic of China
API:	Advance Passenger Information
US/EDIFACT:	United States Electronic Data Interchange for Administration, Commerce, and Transport
ADAPIS:	Airport Departure and Arrival Passenger Information System
MPS:	The Ministry of Public Security of the People's Republic of China
UN/EDIFACT:	United Nations Electronic Data Interchange for Administration, Commerce, and Transport
WCO:	World Customs Organization
IATA:	International Air Transport Association
ICAO:	International Civil Aviation Organization
ISO:	International Organization for Standardization
EDIFACT:	Electronic Data Interchange for Administration, Commerce and Transport
SITA:	Société Internationale de Télécommunications Aéronautiques
FPM:	Flight Passenger Manifest
FCM:	Flight Crew Manifest
MCL:	Master Crew List
STD:	Scheduled Time of Departure
STA:	Scheduled Time of Arrival
PNR:	Passenger Name Record
MRTD:	Machine Readable Travel Document
MRZ:	Machine Readable Zone
IATCI:	Inter Airlines Through Check-in